

### Electro-hydraulic Servo Valve Driver Servo Amplifier

#### Features

- ① Compact design.
- ② Capable of driving virtually all NACHI-MOOG servo valve series.
- ③ Power supply support for 24V DC in addition to 100V AC and 200V AC.

#### Specifications

Item	Description
Number of Inputs	4 (RF-P,FB1-N,FB2-N,FB3-P)
Input Voltage Range	±10VDC (Command Signal/ Feedback Signal)
Input Impedance	50kΩ
Gain Adjust (GAIN)	1 to 20 X/5 to 100 X switchable
Zero Adjust (NULL)	0 to ±20%
Frequency Characteristics	-3dB attenuation at 700Hz
Dither	100 to 400Hz variable (Factory default; 200Hz)
Power Supply Voltage	AC100, 110, 200, 220V (±10%) 50/60Hz
Power Consumption	20VA
External power supply	+15V (200mA) -15V (200mA)
Allowable Ambient Temperature	0 to 50°C
Temperature Drift	50μV/°C max.
Weight	3kg
Servo Valve Coil Drive Current	± 15mA(100Ω) ± 40mA( 40Ω) ±100mA( 14Ω) ±150mA( 14Ω) It is possible to switch the output voltage ±10V for the four types noted above. Resistance values in parentheses indicate resistance in the case of parallel wiring of the servo valve coil.

#### Explanation of model No.

**EA - P D4 - A100 - \*\* - 10**

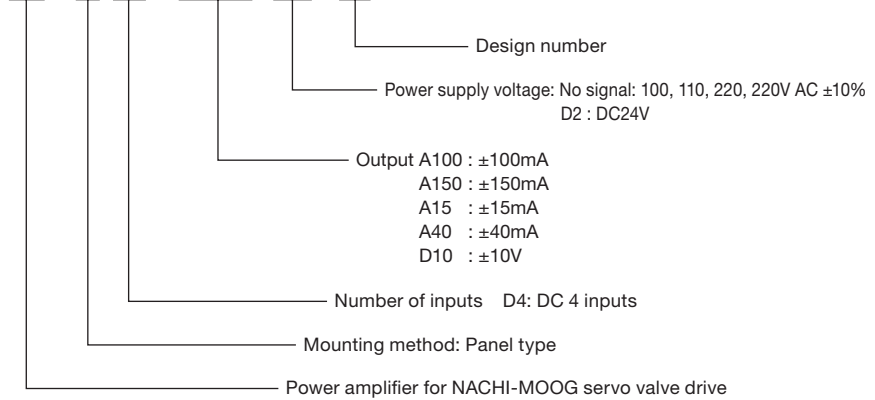

Note: 24V DC only can be used in the case of power supply voltage signal D2. 100V, 200V AC cannot be used.

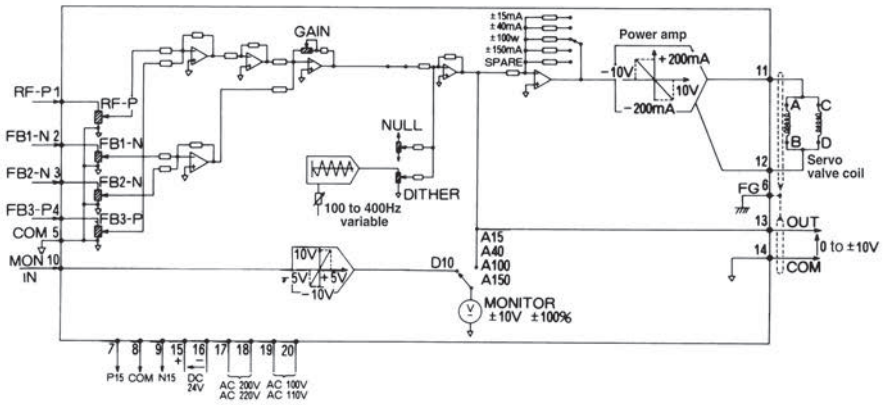

No.	Name	No.	Name
1	RF-P input	11	Control current
2	FB1-N- feedback input	12	Output terminal
3	FB2-N- feedback input	13	Control voltage
4	FB3-P- feedback input	14	Output terminal
5	COM signal land	15	+ DC24V
6	FG case ground	16	- DC24V
7	P15 external power supply	17	AC200, 220V
8	COM signal land	18	AC200, 220V
9	N15 external power supply	19	AC100, 110V
10	MON/IN monitor in	20	AC100, 110V

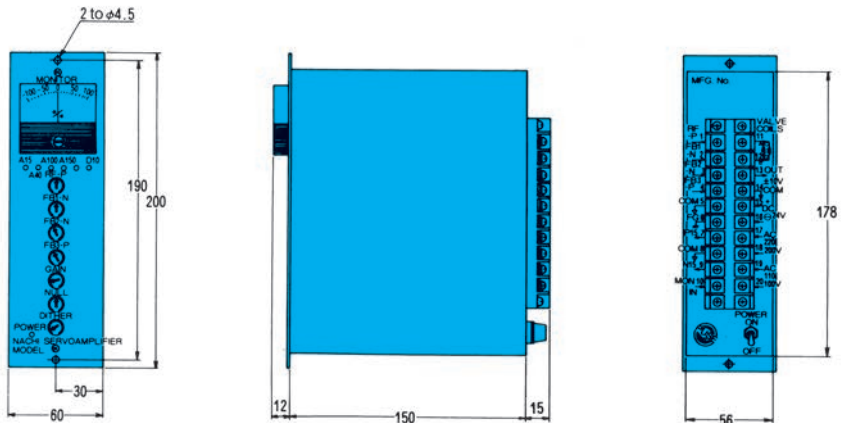

# Servo Valve and Applicable Servo Amplifier Models

Servo Model Number	Rated Output	Applicable Servo Amplifier Model Number
EN-J631 Series	±100mA (parallel wiring)	EA-PD4-A100
EN-J631 Series Center Flow 75 l/min Rated Models	±150mA (parallel wiring)	EA-PD4-A150
EN-J072-401, EN-J072-402, EN-J073-401, EN-J073-402, EN-J073-403, EN-J073-404, EN-J073-405, EN-J076-401, EN-J076-402, EN-J076-403, EN-J076-404, EN-J076-405	±15mA (parallel wiring)	EA-PD4-A15
EN-J072-403, EN-J770, EN-J073-406, EN-J076-406	±40mA (parallel wiring)	EA-PD4-A40
EN-J661 EN-J662 (Main Valve Position Detector or AmP Built In) EN-J663	±10V	EA-PD4-D10

## Wiring Diagram

EN-J631, J072, J073, J076, J770 Series

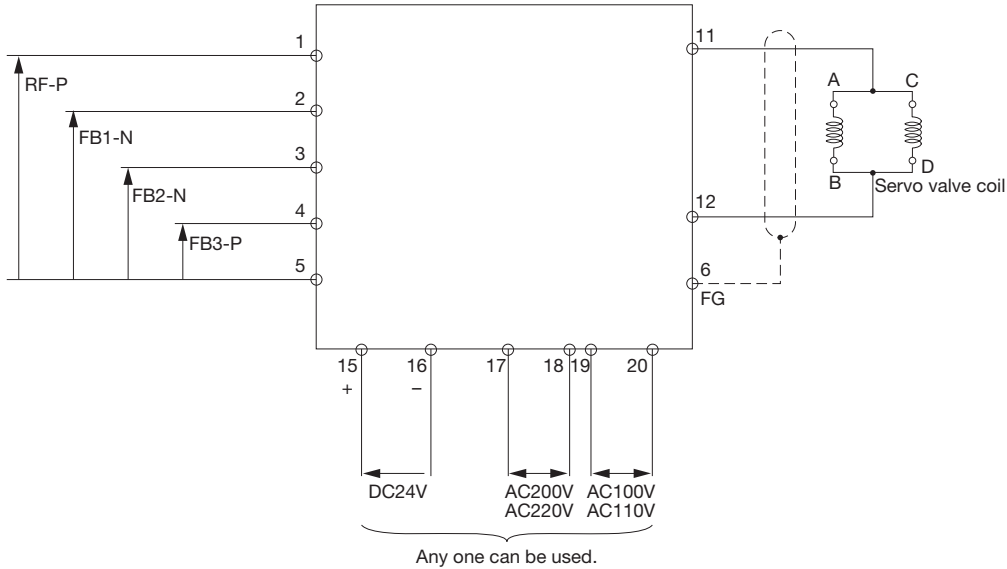

EN-J661, J662, J663 Series

