

Programming tool
PC-based Teaching Tool Standard

- Software for robot setting, programming and debugging.
- User can manage setting and program files based on the project.
- Exclusive editor for robot language
- User can easily manage and input signal, position and parameter.
- User can control the robot without teach pendant.

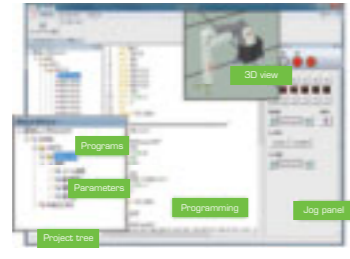

Off-line simulation tool
FD on Desk Light Standard

■ Best simulator for a feasibility study.

- Off-line programming
- Operation and layout study
- Cycle time simulation
- PLC program editing
- Operation instruction



Graphic User Interface
Flex-GUI Option

- Customizable teach pendant screen menu.
- Works as a system operation console which can control peripheral devices.



Support for Various Fieldbus Option

- DeviceNet (master, slave)
- EtherNet/IP (master, slave)
- EtherCAT (slave)
- CC-Link (master, slave)
- PROFIBUS (master, slave)
- PROFINET (slave)

DeviceNet and EtherNet/IP are trademarks of ODVA. (Open DeviceNet Vendor Association, Inc.)
 EtherCAT is trademarks of Beckhoff Automation GmbH.
 CC-Link is a trademark of CC-Link association. (CC-Link Partner Association: CLPA)
 PROFIBUS and PROFINET are trademarks of PROFIBUS & PROFINET International.

Application Examples

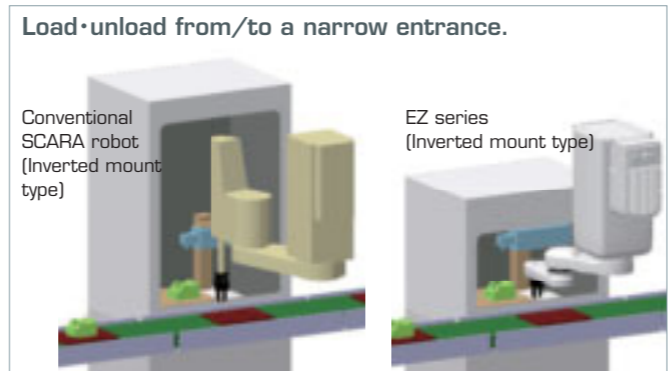
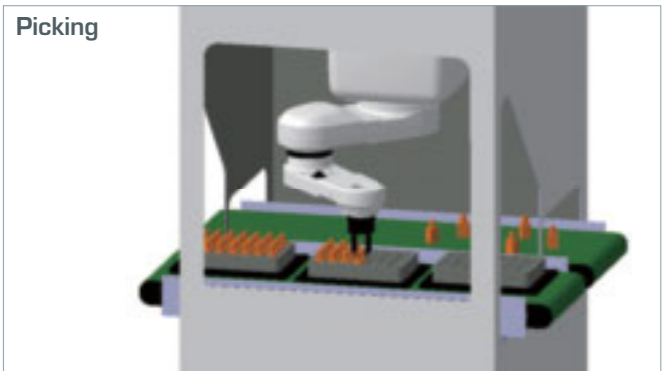

NACHI

NACHI-FUJIKOSHI CORP.

www.nachi.com

Head Office Shiodome Sumitomo Bldg. 17F, 1-9-2 Higashi-Shinbashi, Minato-ku, Tokyo 105-0021
Robot Division 1-1-1 Fujikoshi-Honmachi, Toyama 930-8511, JAPAN

Tel: +81-(0)3-5568-5247
 Tel: +81-(0)76-456-2223
 Fax: +81-(0)3-5568-5237
 Fax: +81-(0)76-493-5251

NACHI ROBOTIC SYSTEMS INC.	Michigan, U.S.A.	Tel: +1-248-305-6545	Fax: +1-248-305-6542	http://www.nachirobotics.com
NACHI CANADA INC.	CANADA	Tel: +1-905-660-0088	Fax: +1-905-660-1146	http://www.nachicanada.com/
NACHI MEXICANA, S.A. DE C.V.	MEXICO	Tel: +52-442-153-2424	Fax: +52-442-153-2435	http://www.nachi.com.mx/
NACHI BRASIL LTDA.	BRASIL	Tel: +55-11-4793-8800	Fax: +55-11-4793-8870	http://www.nachi.com.br/
NACHI EUROPE GmbH	GERMANY	Tel: +49-(0)2151-65046-0	Fax: +49-(0)2151-65046-90	http://www.nachirobotics.com.eu/
NACHI TECHNOLOGY (THAILAND) CO., LTD.	THAILAND	Tel: +66-2-714-0008	Fax: +66-2-714-0740	http://www.nachi.co.th/
NACHI SINGAPORE PTE. LTD.	SINGAPORE	Tel: +65-65587393	Fax: +65-65587371	http://www.nachinip.com.sg/
PT.NACHI INDONESIA	INDONESIA	Tel: +62-21-527-2841	Fax: +62-21-527-3029	http://www.nachi.co.id/
NACHI TECHNOLOGY INDIA PVT. LTD.	INDIA	Tel: +91-(0)12-4450-2900	Fax: +91-(0)12-4450-2910	
NACHI (AUSTRALIA) PTY. LTD.	N.S.W. AUSTRALIA	Tel: +61-(0)2-9898-1511	Fax: +61-(0)2-9898-1678	http://www.nachirobotics.com.au/
NACHI (SHANGHAI) CO., LTD.	CHINA	Tel: +86-(0)21-6915-2200	Fax: +86-(0)21-6915-5427	http://www.nachi-china.com.cn/

● The specifications are subject to changes without notice.
 ● In case that an end user uses this product for military purpose or production of weapon, this product may be liable for the subject of export restriction stipulated in the Foreign Exchange and Foreign Trade Act. Please go through careful investigation and necessary formalities for export.



Unique mechanism is employed in the robot body.

Z-axis Moving Structure

Z-axis structure (along which whole arm moves) makes its arm compact.



Slim Horizontal Arm

Slim, light weight and high speed operation is possible due to no servomotor in the robot arm.



Cut Back on Equipment (Example of Tablet Assembly Line)

Line width reduced by 30 %. Work space reduced by 40 %. Reduce the amount of equipment significantly.

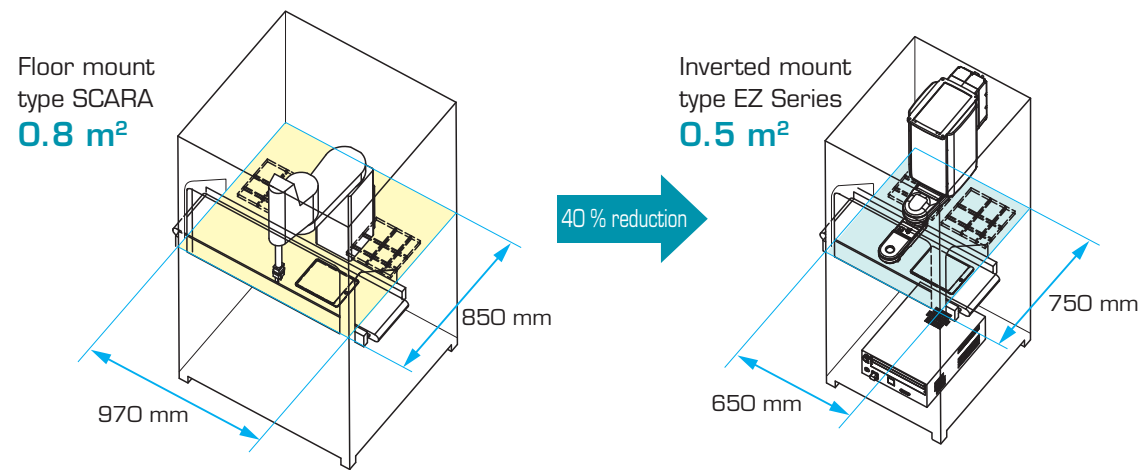

Wide Operating Envelope

The small horizontal arm permits a wide operation envelope and compact layout.

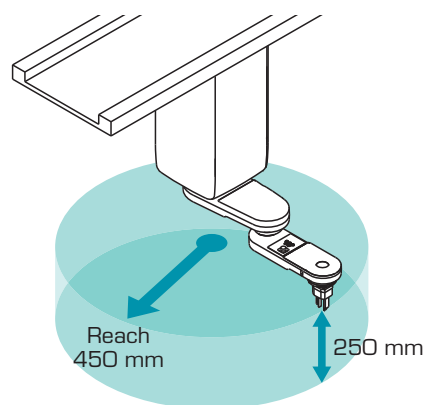

360° operating envelope. Eliminates center dead zone inaccessible by conventional SCARA robots.

High Speed with Shortest Path (Example of Tablet Assembly Line)

Potentially reduce cycle time by up to 30 % (compared to a floor mount type SCARA).

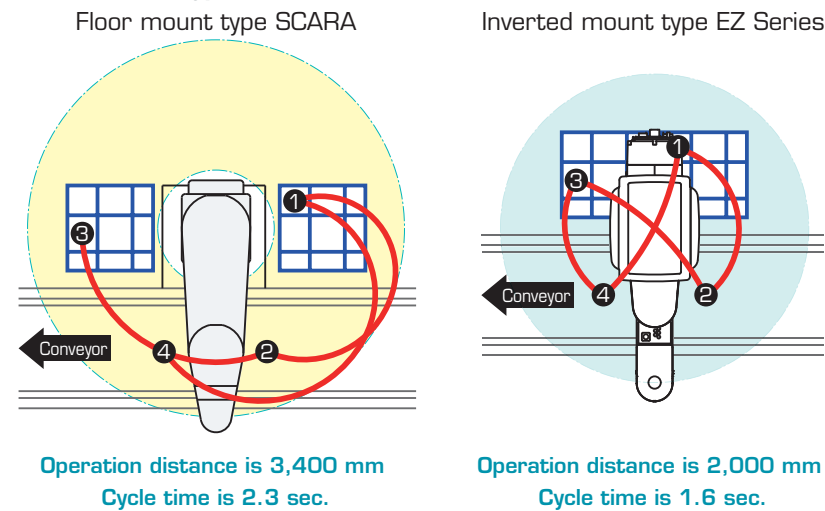

Smart Cable Routing

With the smart cable routing feature, risk of cable interference with peripheral devices is reduced and the operational reliability is significantly improved.

Floor mount type SCARA
 Wires and tubes are routed outside

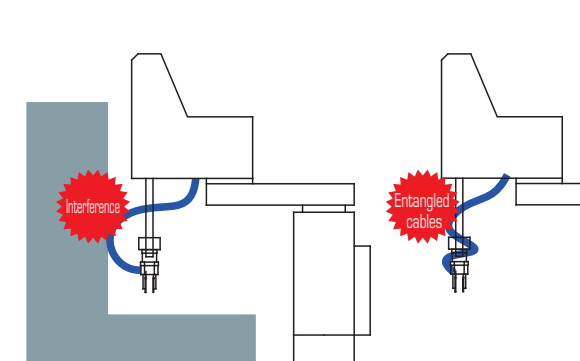

Inverted mount type EZ Series
 Wires and tubes are routed through the hollow wrist

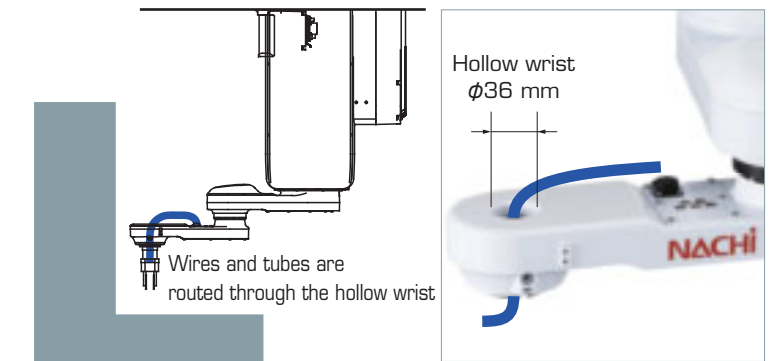

Various Lineup

User can select a combination of following types and Z-axis strokes; Inverted mount/Floor mount and 250 mm/150 mm strokes.



6 axis specifications (EZ02)

Dexterous operation is possible to add 2-axis structure to tip of robot.



Compact Controller

Just 369 mm wide Multi-controller CFDL can be placed within the support structure.

- It can control up to 4 robot unit.
- Emergency stop and operation switches are provided for each 4 unit independently. (they can work in synchronous manner too.)

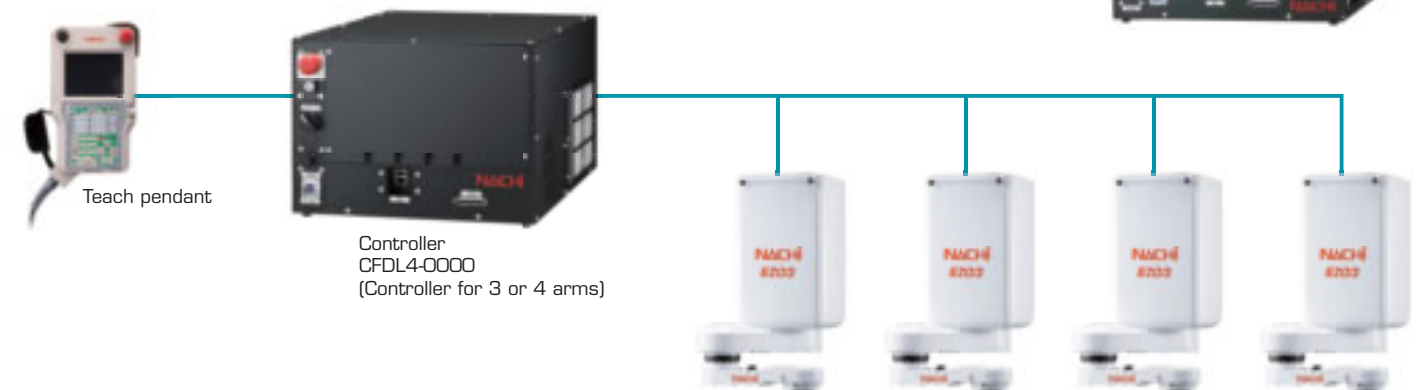

Standard Specifications

Robot model

EZ **-02-**

Basic specifications			
Mark 1	Mark 2	Mark 3	Notes
03	V	4	3 kg payload, inverted mount, 4 axis
	F	4	3 kg payload, floor mount, 4 axis
02	V	6	2 kg payload, inverted mount, 6 axis
	F	6	2 kg payload, floor mount, 6 axis

Arm variation				
Mark 1	Max. reach	Mark 2	Vertical axis stroke	Notes
45	450 mm	15	150 mm	Inverted mount
		25	250 mm	
55	550 mm	15	150 mm	Floor mount
		25	250 mm	

Robot specifications

Item	Specifications																	
Robot model	EZ03V4-02-4515		EZ03V4-02-4525		EZ03F4-02-5515		EZ03F4-02-5525		EZ02V6-02-4515		EZ02V6-02-4525		EZ02F6-02-5515		EZ02F6-02-5525			
Structure	Horizontal articulated																	
Number of axis	4				6													
Max. reach	450 mm				550 mm				450 mm				550 mm					
Installation ¹	Inverted mount				Floor mount				Inverted mount				Floor mount					
Drive system	AC servo system																	
Max. operating envelope	J1	Vertical	150 mm	250 mm	150 mm	250 mm	150 mm	250 mm	150 mm	250 mm	150 mm	250 mm	150 mm	250 mm	150 mm	250 mm		
	J2		±170°															
	J3		±180°				±145°				±180°				±145°			
	J4		±360°															
	J5										±105°							
	J6										±360°							
Max. speed ²	J1	Vertical	1200 mm/s	1400 mm/s	1200 mm/s	1400 mm/s	1000 mm/s	1200 mm/s	1000 mm/s	1200 mm/s	1000 mm/s	1200 mm/s	1000 mm/s	1200 mm/s	1000 mm/s	1200 mm/s		
	J2		450°/s															
	J3		720°/s															
	J4		2400°/s								1200°/s							
	J5										720°/s							
	J6										720°/s							
Payload (max)	2 kg (3 kg)				1 kg (2 kg)													
Allowable moment of inertia for wrist ³	J4		0.05 kg·m ² (0.005 kg·m ² rated)								0.03 kg·m ² (0.013 kg·m ² rated)							
	J5										0.03 kg·m ² (0.013 kg·m ² rated)							
	J6										0.01 kg·m ² (0.001 kg·m ² rated)							
Position repeatability ⁴	±0.014 mm				±0.02 mm													
Air piping									φ 6x2									
Application wirings									10 wires									
Installation conditions	Ambient temperature: 0 to 45°C ⁵ Ambient humidity: 20 to 85% RH (without condensation) Allowable vibration of installation surface: Not more than 0.5 G (4.9 m/s ²)																	
Environmental conditions ⁶	IP20																	
Noise level ⁷	70 dB																	
Robot mass	42 kg				43 kg				44 kg				45 kg					

1 [rad] = 180/π[°], 1 [N · m] = 1/9.8 [kgf · m]

*1: The maximum speed in the chart is a maximum value. The maximum value may change depending on work programs and load conditions of the wrist.

*2: The allowable moment of inertia of a wrist changes with the load conditions of a wrist.

*3: JIS B 8432 compliant.

*4: Using at 1000 m or lower sea level. Ambient temperature has limitations when allowable altitude is exceeded.

*5: Fluids that cause the deterioration of sealants, such as gasoline-based cutting fluids, chlorine, alkali, acids, and organic solvents, cannot be used.

*6: A-weighted equivalent sound level measured according to JIS Z 8737-1 (ISO 11201). (while operating at maximum speed with rated load)

Application connector

	6	5	4	3	2	1
D	G	A20	A19	A18	A17	A16
C		A15	A14	A13	A12	A11
B		A22	A10	A09	A08	A07
A		A21	A05	A04	A03	A02

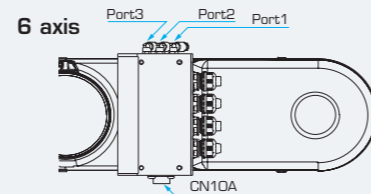
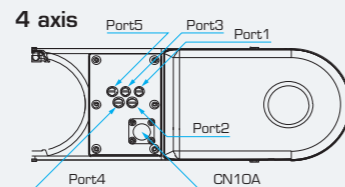
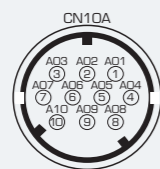

Robot dimensions and operating envelope

Inverted mount

	a	b
EZ03V4-02-4525	665	250
EZ03V4-02-4515	565	150
EZ02V6-02-4525	730	250
EZ02V6-02-4515	630	150

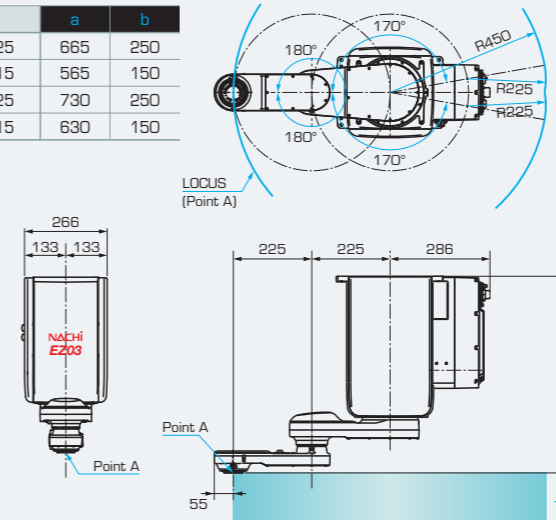

Floor mount

	c	d
EZ03F4-02-5525	420	250
EZ03F4-02-5515	320	150
EZ02F6-02-5525	335	250
EZ02F6-02-5515	255	150

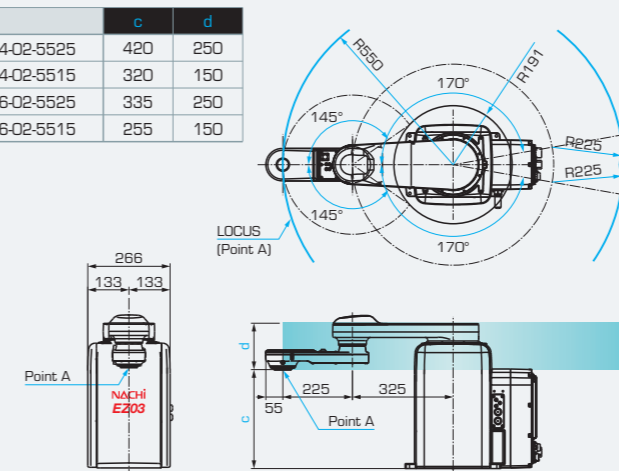

Wrist dimensions

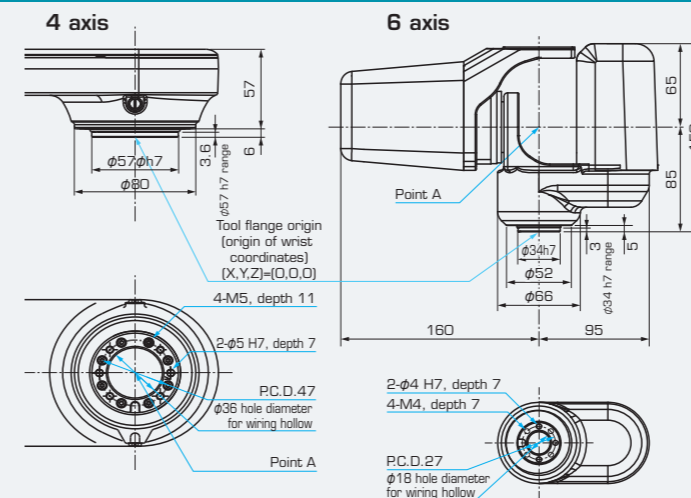

Basic specifications of controller

Item	Specifications		
	CFDL1-0000	CFDL2-0000	CFDL4-0000
Model			
Maximum controllable units	1 unit	2 units	4 units
Maximum controllable axis	6 axis/unit		
Compatible motor	AC servo motor		
Compatible encoder	17-bit absolute encoder		
Safety performance	PLd Category-3, *ISO10218 compliant		
Teach pendant	Option		
Operating switches	Emergency stop, mode switching		
Relay unit	8		
W/H	2, 5, 10, 15, 20 m		
External dimensions	369 (W) × 490 (D) × 187 (H) 369 (W) × 510 (D) × 263 (H)		
Protection rating	IP20		
Power supply	Single phase/3φ 200-230 VAC		
Ambient temperature	0 to 40°C (50/60 Hz)		
Ambient humidity	20 to 85% (without condensation)		

Controller options

Item	Specifications		
	CFDL1-0000	CFDL2-0000	CFDL4-0000
Model			
External memory	USB memory		
Network	Ethernet		
PCI option	2 slots	1 slot	
Fieldbus	DeviceNet, PROFIBUS, EtherCAT, CC-Link, and others EtherCAT and CC-Link are only compatible as a slave		
Digital I/O	Maximum 64/64		
Software PLC	Yes		
Built-in visual sensor	Option		
Brake release	Brake release mode		
Mechanism conversion	No		
Overseas compliance	UL, CE, KCs		
Welder I/F	None (not compliant with RWC, MEDAR, etc.)		

Installation dimensions

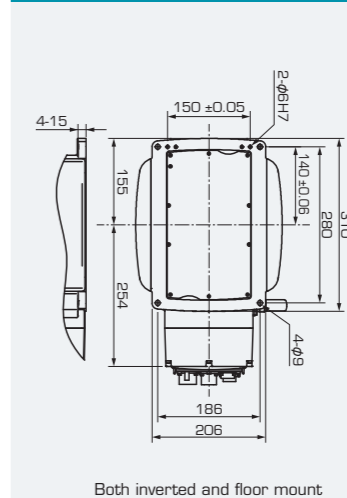

Controller dimensions

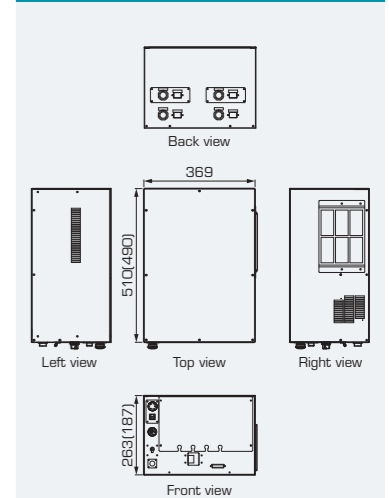

Options

Option drawings

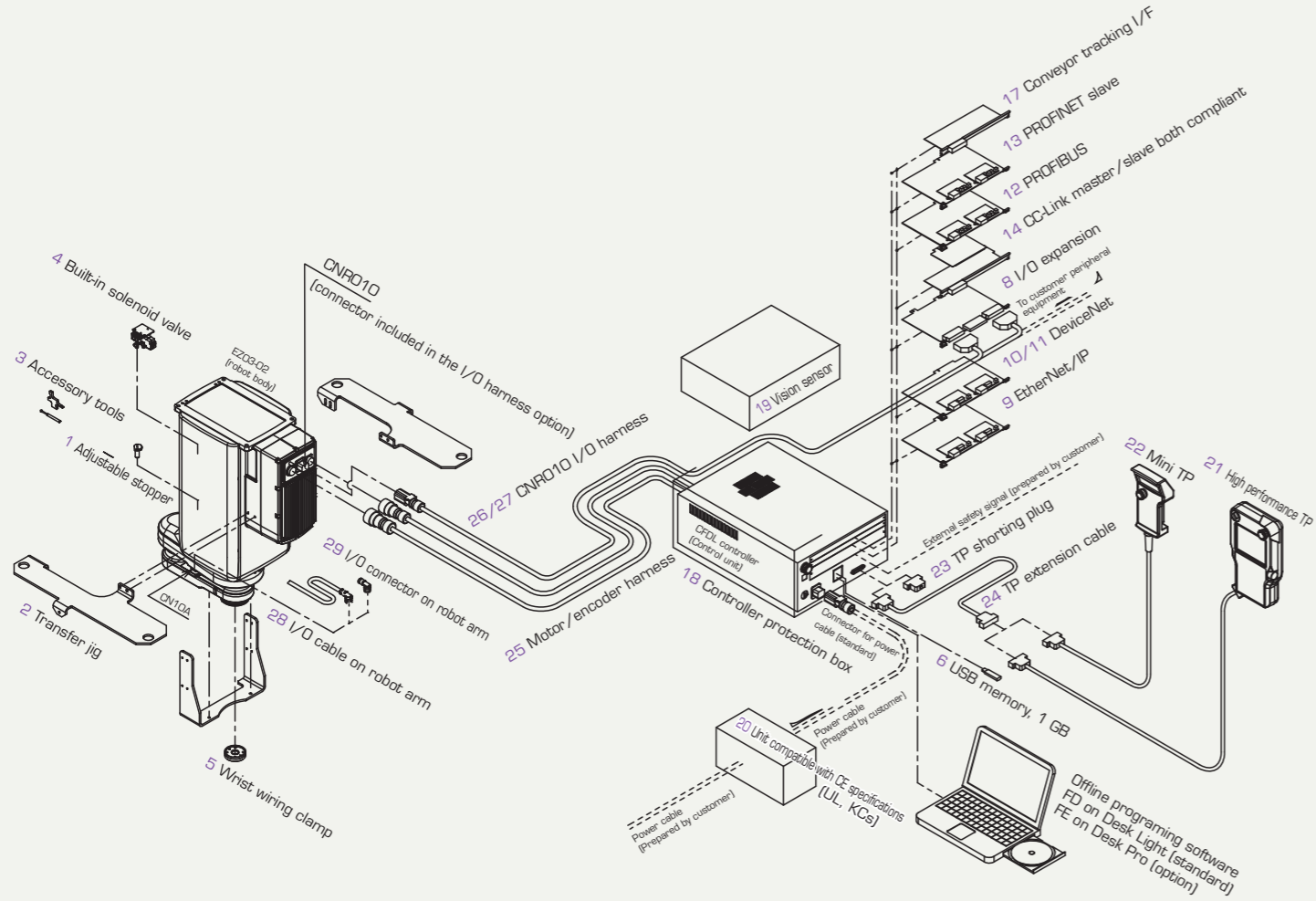

- Options are installed by customer according to their installation instruction manual.
- TP is an acronym for teach pendant

Wiring and piping inside machine body

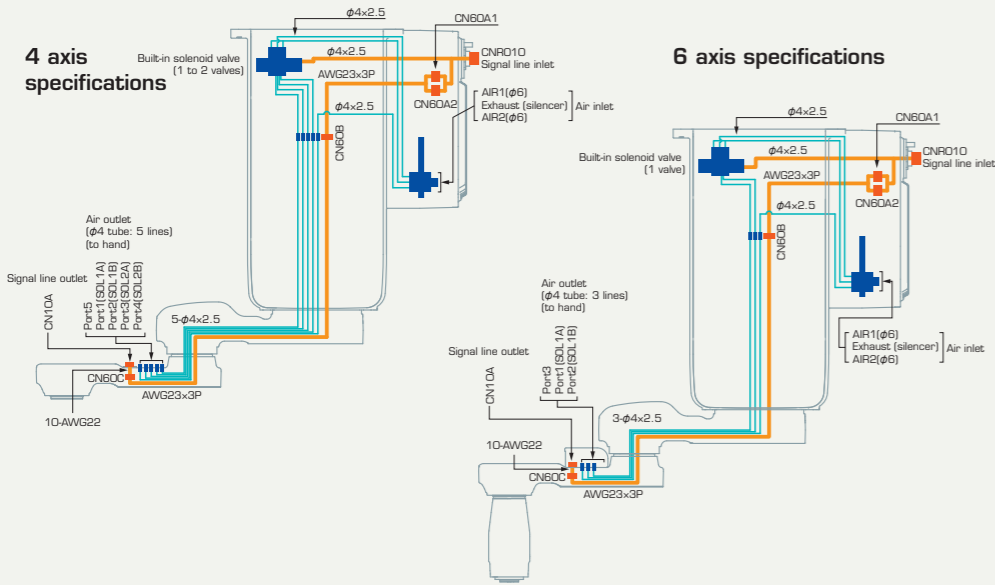

Wrist dimensions (option 5)

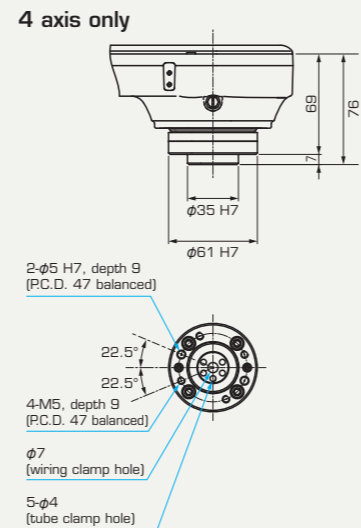

Option list

No.	Product name	Specifications	Parts No.	Notes
1	Adjustable stopper	For number 2 axis	OP-S5-032	
2	Transfer jig	For both crane transport and inverted mount jig	OP-S2-049	
3	Accessory tools	For 4 axis, zeroing pin and block For 6 axis, zeroing pin and block	OP-T2-099	For 1 to 4 axis
4	Built-in solenoid valve	1 valve (4 and 6 axis specifications) 2 valves (4 axis specifications)	OP-T2-094 OP-H4-009 OP-H5-011	For 1 to 6 axis Pressure range 0.1 to 0.5 MPa Coil voltage rating 24 VDC
5	Wrist wiring clamp	Wire/tube clamp for hollow in number 4 axis	OP-W3-018	Air (φ4, 5 lines), signal lines (4-axis only)
6	USB memory	1 GB	FD11-0P93-A	
7	Compact I/O board	8 point/8 point (relay output)		Equipped on sequence board
8	I/O expansion	I/O 32 point/32 point (NPN 1 board expansion) I/O 64 point/64 point (NPN 2 board expansion) I/O 32 point/32 point (PNP 1 board expansion) I/O 64 point/64 point (PNP 2 board expansion)	CFD-OP125-A CFD-OP125-B CFD-OP151-A CFD-OP151-B	Occupies 1 slot Occupies 2 slots Occupies 1 slot Occupies 2 slots
9	EtherNet/IP	Master 1CH Slave 1CH Master 1CH + Slave 1CH	CFD-OP130-A CFD-OP130-B CFD-OP130-C	Occupies 1 slot
10	DeviceNet	Master 2CH Slave 2CH Master 1CH + Slave 1CH	CFD-OP130-D CFD-OP130-E CFD-OP131-A CFD-OP131-B CFD-OP131-C CFD-OP131-D	Occupies 1 slot
11	DeviceNet (quick connect)	Master 2CH Slave 1CH Master 1CH + Slave 1CH	CFD-OP131-E CFD-OP129-A CFD-OP129-B CFD-OP129-C CFD-OP129-D CFD-OP129-E	Occupies 1 slot
12	PROFIBUS	Master 1CH Slave 1CH Master 1CH + Slave 1CH	CFD-OP132-A CFD-OP132-B CFD-OP132-C CFD-OP132-D CFD-OP132-E	Occupies 1 slot
13	PROFINET	Slave 1CH Slave 2CH	CFD-OP136-B CFD-OP136-D	Occupies 1 slot
14	CC-Link	Both master and slave supported 1CH	CFD-OP98-B	Occupies 1 slot
15	FL-net	1CH	CFD-OP101-B	Occupies 1 slot
16	Analog output	Analog output 4CH	CFD-OP46-B	Occupies 1 slot
17	Conveyor tracking I/F	RS422 Differential input encoder counter	CFD-OP47-A	Occupies 1 slot
18	Controller protection box	1 to 2 units (CFDL1, CFDL2) 4 units (CFDL4)	CFD-OP133-A CFDL-OP133-A	IP54 protection class compliant (dust-proof and drip-proof box)
19	Vision sensor	Vision sensor unit for CFD (separate installation), cross laser Vision sensor unit for CFD (separate installation), monocular/stereo camera Vision sensor unit for CFD (separate installation), 2 LED Vision sensor unit for CFD (separate installation), 3D	CFD-OP139-A CFD-OP139-B CFD-OP139-C CFD-OP139-D	
20	UL specifications	UL standard compliant	CFDL-UL-A	
	CE specifications	CE marking compliant	CFDL-CE-A	
	KCs specifications	Korean KCs compliant	CFDL-KCS-A	
21	High performance TP	Cable length 4 m	CFDTP-10-04M	Select one from 21, 22, or 23.
22	Mini TP	Cable length 4 m	MINITP-10-04M	
23	TP shorting plug	To disconnect teach pendant	CFD-OP153-A	
24	TP extension cable	5 m 10 m 15 m 20 m	CFDTP-RC05M CFDTP-RC10M E000E-J1-02-B E000E-J1-05-B E000E-J1-10-B E000E-J1-15-B E000E-J1-20-B	User can choose either one connector on both ends. It is necessary to select one of them.
25	Motor/encoder harness	2 m 5 m 10 m 15 m 20 m	IOCCABLE-10-02M IOCCABLE-10-05M IOCCABLE-10-10M IOCCABLE-10-15M IOCCABLE-10-20M IOCCABLE-10-25M	I/O cable between robot and controller. Controller side is open-ended. User needs to connect wires to match appropriate signals.
26	CNR010 I/O harness (loose wires for controller connections on robot side)	2.5 m 5.5 m 10.5 m 15.5 m 20.5 m 25.5 m	IOCCABLE-40B-02M IOCCABLE-40B-05M IOCCABLE-40B-10M IOCCABLE-40B-15M IOCCABLE-40B-20M IOCCABLE-40B-25M	I/O cable between the robot and sequence I/O board (NPN type) in the controller.
27	CNR010 I/O harness Relay output supported (both terminals connected to controller on robot side)	2.5 m 5.5 m 10.5 m 15.5 m 20.5 m 25.5 m	IOCCABLE-20-00 IOCCABLE-30-1-02M IOCCABLE-30-1-05M IOCCABLE-30-1-10M IOCCABLE-30-1-15M IOCCABLE-30-1-20M IOCCABLE-30-1-25M	Customer recommended to complete wiring on application side. Can be used with CFD-OP125-A or CFD-OP151-A.
28	I/O cable on robot arm	1.5 m	IOCCABLE-20-Q1M	
29	I/O connector on robot arm	Connector only, connectors are soldered type	IOCCABLE-20-Q0	
30	32-contact I/O harness (connected to controller connector, customer side is loose wires)	2.5 m 5.5 m 10.5 m 15.5 m 20.5 m 25.5 m	IOCCABLE-30-2-02M IOCCABLE-30-2-05M IOCCABLE-30-2-10M IOCCABLE-30-2-15M IOCCABLE-30-2-20M IOCCABLE-30-2-25M	Customer recommended to complete wiring on application side. Can be used with CFD-OP125-B or CFD-OP151-B.
31	64-contact I/O harness (connected to controller connector, customer side is loose wires)	2.5 m 5.5 m 10.5 m 15.5 m 20.5 m 25.5 m	IOCCABLE-30-2-02M IOCCABLE-30-2-05M IOCCABLE-30-2-10M IOCCABLE-30-2-15M IOCCABLE-30-2-20M IOCCABLE-30-2-25M	Customer recommended to complete wiring on application side. Can be used with CFD-OP125-B or CFD-OP151-B.
32	Power voltage converter	CFDL1-0000, CFDL2-0000 CFDL4-0000	CFD-OP154-A CFDL-OP154-A	Portable transformer for 100 VAC